

INSTRUCTIONS FOR USE
EDWARDS HIGH VACUUM EVAPORATOR
(Metal only)

1. Sign in The Record Book. NOTE: As you progress through each step, the machine will "prompt" you by lighting up buttons that are available to push.

STARTING

2. Go to the adjacent Confocal room and turn on the pump coolant water labeled "EDWARDS"
3. Turn on the POWER (switch from 0 to 1, ① in diagram, next page) The display ③ will read "POWER FAIL".
4. Push RESET, the display should show "STANDBY"
5. Push START, the display will cycle through "PUMPS ON", "BACKING", "TURBO-START", and "SEALED".
6. As the machine cycles through these pumping stages, charge the machine with liquid nitrogen through the side port (see diagram, next page).

SAMPLE AND FILAMENT PREPARATION

7. Once "SEALED" is displayed, push VENT
8. Wait approximately 2 minutes and then unlatch the bell jar's support arm and, keeping both hands on the handles, carefully lift the jar and swing it out of the way.
9. Put on the white gloves
10. Wash a new basket/metal filament with acetone and allow to dry. Remove the hex screw from the filament cover, remove the cover and loosen the hex screws on the underside of the filament clamps. Remove the old filament (if present) and replace with a new filament basket loaded with the metal to be evaporated.
Then reposition the loaded filament so the basket is centered in relation to the hole in the support arm above the basket. Reassemble the filament holder and cover. The arm of the filament assembly can be moved to center the filament basket over the sample. Be sure that it is tightened securely.
11. Place the specimen(s) in the rotating holder below the filament and center the filament basket over your sample.

PUMP DOWN AND COATING

12. After making sure that everything is secure, lower the bell jar and snap back into place. The control panel should then light up several choices.
13. Press PROCESS. The display should then cycle through "ROUGHING", "PUMP DOWN", and "FINE PUMPING".
14. Once the pump down has reached 2.7×10^{-6} , Make sure that the variable transformer is at ZERO.
15. Make sure the Selector is on A (for 10V), and switch the LT/HT selector to LT.

16. Slowly increase the variable transformer until the expected current is reached and a fine layer of metal is deposited on the sample(s).

17. Turn down the variable transformer to ZERO. Switch the LT/HT to OFF.

UNLOADING THE CHAMBER AND SHUTTING DOWN

18. Press SEALED.

19. Press VENT.

20. Repeat the process for step 8, 9, and 12; removing your samples before closing the bell jar.

21. Press CYCLE.

22. Wait for pressure to fall to 3.4×10^{-4} , Then press SEAL and STOP. The display will read "TURBO STOP" and then "STANDBY"

23. Wait 20 minutes, then turn off the main switch (① to 0) and turn off the cooling water.

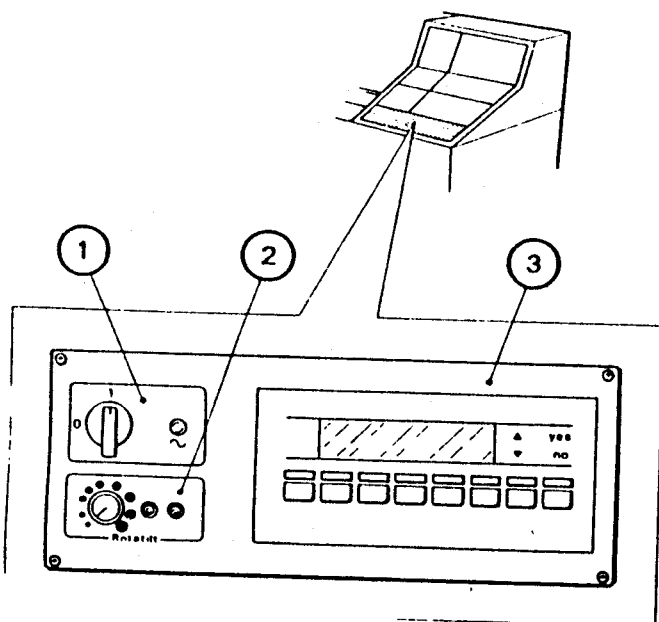

1. Mains Switch
2. Rotatilt Controller
3. AUTO 306 Controller

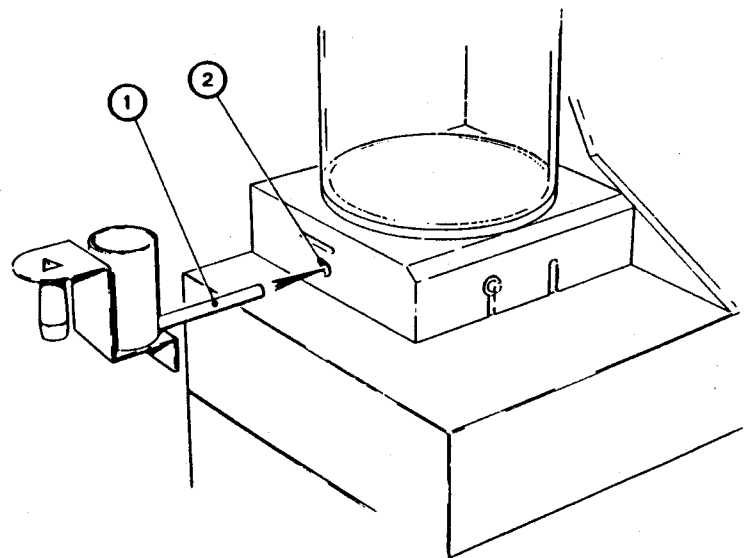

1. Liquid Nitrogen Filler
2. Trap Entry Tube

Figure 19 - Filling with Liquid Nitrogen